

FIBONACCI IDENTITIES DERIVED FROM PATH COUNTING IN AUTOMATA

ARTHUR BENJAMIN AND DALE GERDEMANN

1. INTRODUCTION

Combinatorial proofs are appealing since they lead to intuitive understanding. Proofs based on other mathematical techniques may be convincing, but still leave the reader wondering why the result holds. A large collection of combinatorial proofs is presented in [1], including many proofs of Fibonacci identities based on counting tilings of a one-dimensional board with squares and dominoes. An alternative approach, much in the same spirit, is to base proofs on automata that recognize, i.e., accept, such tilings. Although many of the same results can be obtained, we will show here that the automata-based approach in some cases has interesting advantages.

As a simple example, we may start with a deterministic finite state automaton in Figure 1, which corresponds very directly to square-domino tilings.

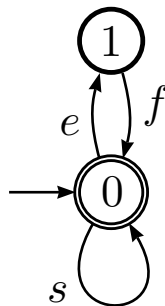

FIGURE 1. A minimal tiling automaton.

The automaton in Figure 1 is deterministic, as are all automata considered in this paper. The automaton has two states: state 0, which is initial and final, and state 1, which is neither initial nor final. The unique (because of determinism) initial state is designated by the arrow incoming from the left; a permissible final state has a double circle. The alphabet, which will be used throughout this paper, is $\{s, e, f\}$, where s stands for a square, e for the first half of a domino and f for the second half of a domino. The domino is thus “broken in half” so that path length in the automaton corresponds to board length in a square-domino tiling. We let f_n count the number of words of length n . With $n = 4$, for example, we have the words $\{ssss, ssef, sefs, efss, efef\}$. The word $ssef$, for example, is recognized

by the following sequence of transitions: $0 \xrightarrow{s} 0$, $0 \xrightarrow{s} 0$, $0 \xrightarrow{e} 1$, $1 \xrightarrow{f} 0$. Clearly, $f_n = F_{n+1}$, the $n + 1^{\text{st}}$ Fibonacci number.

Since the automaton in Figure 1 is deterministic, each recognized word corresponds to exactly one path. Moreover, the automaton in Figure 1 is minimal. There is no finite state automaton for this language with fewer than two states. But there are infinitely many non-minimal automata for the language with more than two states. For example, the automaton in Figure 2 recognizes the same language (i.e., generates the same set of legal words). Here a word ends at state 0 if it has even length, and ends at state 1 if it has odd length.

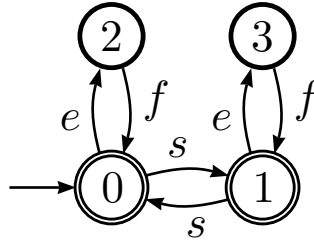

FIGURE 2. A non-minimal tiling automaton.

Such non-minimal automata can provide inspiration for combinatorial proofs that would not be so apparent otherwise. A non-minimal automaton gives us an alternative view point on the problem. In fact, since there are an infinite number of non-minimal automata recognizing a regular language, we obtain an infinite number of alternative perspectives. As we show in section 3, path counting in an infinite set of automata is a powerful technique, which can be used to obtain a very general identity. First, however, to get a feel for the idea, we consider a few simple path counting examples in section 2.

2. SIMPLE PATH COUNTING EXAMPLES

Fibonacci numbers show up in a huge variety of counting problems, including naturally occurring problems. Many problems can be modeled using automata, which then give us a unified framework for understanding such problems and then using them to derive combinatorial proofs. Consider, for example, one of the classics from the Fibonacci literature [4]. Two panes of glass are stuck together, and we ask how many paths a ray of light may take, given that the ray enters the glass and makes n reflections before leaving. Some examples are seen in Figure 3. It is trivial to show that if a_n counts the number of paths for n reflections, then $a_n = f_{n+1}$.

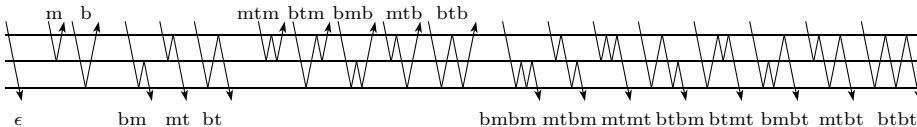

FIGURE 3. Ray of light reflecting in 2 glass panes stuck together.

Suppose we represent reflection patterns as strings over the alphabet $\{t, m, b\}$, indicating a change of direction at the top, middle or bottom, respectively. So, for

example, the paths in Figure 3 from left to right are: ϵ ; m , b ; bm , mt , bt ; \dots (where ϵ represents the empty string). The set of such strings can then be expressed as in the automaton in Figure 4.

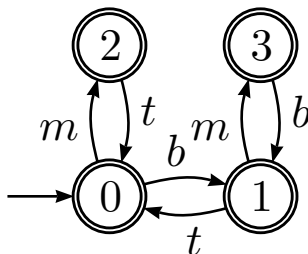

FIGURE 4. Reflection automaton.

What is surprising is that this automaton is essentially a relabeling of the automaton in Figure 2. The difference is that in Figure 4, states 2 and 3 are final, whereas in Figure 2, these states were non-final. The effect of this difference is easy to determine. Let p_n count the number of paths of length n accepted by the reflection automaton, and let $p_{i,n}$ be the number of paths of length n accepted by the reflection automaton which end at state i . Then $p_{2,n} + p_{3,n} = p_{0,n-1} + p_{1,n-1}$. From the non-minimal tiling automaton in Figure 2, we see that $p_{0,n-1} + p_{1,n-1} = f_n$. So $p_{2,n} + p_{3,n} = f_{n-1}$ and $p_n = p_{0,n} + p_{1,n} + p_{2,n} + p_{3,n} = f_n + f_{n-1} = f_{n+1}$.

To see the usefulness of this automaton, we may try conditioning on the first visit of state 3, in paths that visit state 3 at least once and end in state 0 or 1. In the glass pane model, this is equivalent to conditioning on the first midline reflection coming from below in paths that do not end with a reflection off of the midline. We may think of such a pattern as consisting of a prefix, in which state 3 is never visited, followed by an infix, in which state 3 is visited, followed by a suffix, in which any states may be visited. Using a regular expression, we can express this pattern as $((mt) \cup (bt))^* bmb((mb) \cup (t(mt)^*b))(\epsilon \cup t(mt)^*)$.¹ In the non-minimal tiling automaton, the expression can be simplified, since the sequence ef corresponds to a domino, which we represent as d . Thus for the automaton in Figure 2, the regular expression would be $(d \cup (ss))^* sd(s \cup d)^*$. We see here a very restrictive prefix consisting of a repeated pattern of one domino or two squares. Then the infix sd breaks this pattern, so that the suffix may be freely formed. This pattern leads naturally to the following identity.

Identity 1. For $n \geq 2$,

$$f_{2n} - 2^n = \sum_{i=0}^{n-2} 2^i f_{2n-2i-3}$$

¹Regular expressions are discussed in any textbook on formal language theory. The basic idea, however, is simple. A sequence of letters (or *word*) w denotes the *language* (set of strings) $\{w\}$. The empty string (a string of length 0) is denoted by ϵ , so as a regular expression ϵ denotes the language containing just this empty string. If R_1 and R_2 are regular expressions, then the concatenation R_1R_2 denotes the pairwise concatenation of the strings in R_1 with the strings in R_2 . Similarly, $R_1 \cup R_2$ denotes the union of the sets of strings denoted by the two regular expressions. Finally R^* denotes the infinite union $\epsilon \cup R \cup RR \cup RRR \cup \dots$. So, for example, $((mt) \cup (bt))^*$ denotes the set $\{\epsilon, mt, bt, mtmt, mtbt, btmt, btbt, \dots\}$.

Proof. The left hand side counts all tilings of length $2n$ other than the 2^n tilings consisting entirely of repetitions of $(d \cup (ss))$. The right hand side conditions on the length of the prefix which corresponds to this pattern. The prefix can be tiled in 2^i ways, and since the remainder after the prefix and the sd infix is of length $2n - 2i - 3$, this suffix can be tiled in $f_{2n-2i-3}$ ways. \square

Any number of identities can be proved by this pattern. A table of such identities is given in the appendix.

2.1. Waiting in Line. Reflection patterns correspond to square-domino tilings in a rather direct way. For other combinatorial interpretations of Fibonacci numbers, the correspondence may be more indirect. For example, consider a sequence of men and women waiting in line. The women are all sociable and, with the possible exception of the last woman in line, always form groups of at least 3. So the sequence (or *word*) $mwmm$ is bad since there is a group of women of size two, and $wwwmmwm$ is accepted since the singleton woman is the last woman in line. The allowable patterns of men and women is represented by the automaton in Figure 5. This automaton doesn't look at all similar to the non-minimal tiling automaton in Figure 2. Yet, perhaps surprisingly, the number of possible lines of length n turns out to be f_{n+1} .

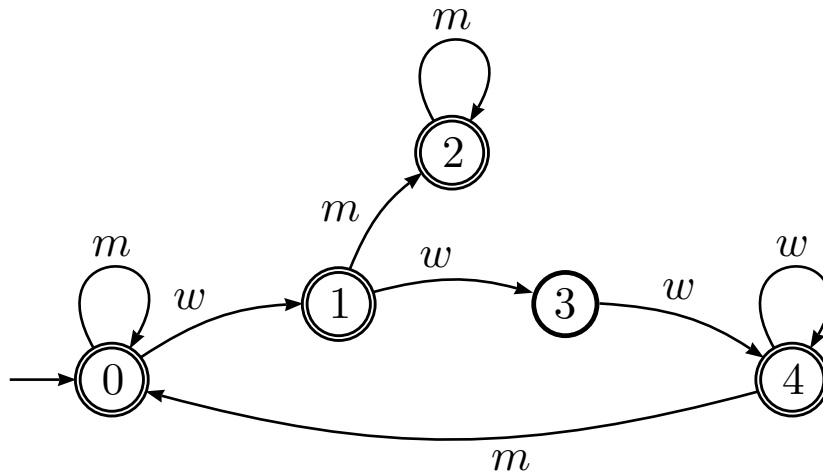

FIGURE 5. Automaton for men and sociable women waiting in line.

The combinatorial interpretation for the men and sociable women (MSW) line holds because there is a one-to-one correspondence between square-domino tilings of length n and MSW lines of length $n - 1$. This is, however, somewhat tedious to show. It is easier to show that the Fibonacci recurrence holds for these lines.

For $n = 0$ there is one well-formed MSW line, and for $n = 1$ there are two such lines: one consisting of a single man, and one consisting of a single woman. For lines longer than 1, there is a rather unusual formation rule, which nevertheless leads to the usual Fibonacci recurrence. Let a_n be the number of MSW sequences of length n . Clearly, there are a_{n-1} MSW sequences that end with m . We next show that there are a_{n-2} MSW sequences that do not end with m . Let X be a MSW sequence of length $n - 2$. If X has no single woman, then we append mw .

If X ends with mw , then we append ww . Otherwise, X ends with a string of the form mwm^j , for some $j \geq 1$. Here, we replace wm^j with mw^{j+3} . These three cases transform X to a length n MSW sequence that ends in a single w , or exactly three ws , or four or more ws , respectively.

The MSW line interpretation is perhaps not the most intuitive combinatorial interpretation for Fibonacci numbers. Nevertheless, it may easily be used in combinatorial proofs. For example, an obvious idea is to condition on the ending location of the first group of women. This leads quite easily to Identity 2.

Identity 2. For $n \geq 0$,

$$f_{n+1} = 1 + n + \sum_{i=3}^n (i-2)f_{n-i}$$

Proof. The left hand side counts the MSW lines of length n . And the right hand side treats three possible cases. First of all, there is one case where the line does not contain any women. Then there are n cases where the line contains a single woman. Then the sum, $\sum_{i=3}^n (i-2)f_{n-i}$, handles the general case where the first group of women is of size 3 or more. Given a prefix of the line of length i ending with a group of women, there $i-2$ positions where this group of women could begin. After the group of women, the remainder of the line is of length $n-i$, and since this remainder must either be empty or start with a man, there are f_{n-i} ways in which this remainder can be formed. \square

2.2. A Three Color Tiling. In the previous two examples, each pair of nodes is connected by at most one transition in each direction. This property will be important in the identity discussed in the next section. First, however, we look at an example where this property does not hold. Consider a tiling with red, white and blue dominoes, and red and white squares, with the following two rules. First, a white tile is not allowed after a blue tile. And second, at most one square can be used, and this square must come at the end. The number of tilings of length n that meet these conditions will be shown to be f_{n+1} . The automaton recognizing such tilings is shown in Figure 6. In this automaton, capital R , W and B abbreviate sequences of two transitions. R , for example, abbreviates a transition over the first half of a red domino, followed by a transition over the second half of a red domino. Lower case r and w represent the red and white squares, respectively.

For this tiling, one can show that the usual Fibonacci recurrence holds in the following manner. First, there is one tiling of length 0, and two tilings of length 1 (a red square, or a white square). The construction to form the set of tilings of length n depends on whether n is even or odd. Assume first that n is even. For each tiling of length $n-2$, add a blue domino to the end. And for each tiling of length $n-1$, replace the final red or white square with a domino of the same color. If n is odd, then for each tiling of length $n-2$ change the final square to a domino of the same color, and then add a w to the end. And for each tiling of length $n-1$, add an r .

It is clear that the square plays a minor role in this tiling. If we eliminate the squares and reduce the dominoes down to squares as in Figure 7, then the number

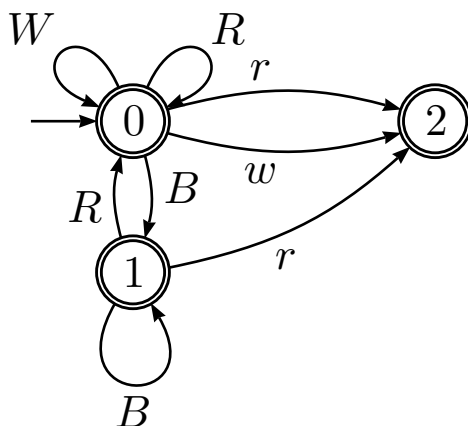

FIGURE 6. Automaton for Three Color Tiling.

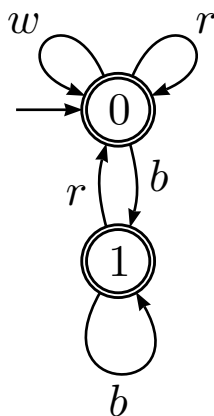

FIGURE 7. Reduced Automaton for Three Color Tiling.

of paths of length n recognized is f_{2n+1} .² Furthermore, for every path of length n recognized by the automaton, there is a path of length $n + 1$, that ends at state 1. Thus the number of paths of length n ending at state 1 is f_{2n-1} . We can use this observation to prove the following identity.

Identity 3. For $n \geq 0$,

$$3^n = f_{2n+1} + \sum_{i=1}^{n-1} 3^{n-i-1} f_{2i-1}$$

Proof. The left hand side counts all sequences of length n over the alphabet $\{r, w, b\}$. On the right hand side f_{2n+1} counts those sequences that are accepted by the

²The tiling in this reduced form corresponds to the pattern examined by [2]. It is also mentioned in [1, p. 14, combinatorial interpretation number 6].

automaton and $\sum_{i=1}^{n-1} 3^{n-i-1} f_{2i-1}$ counts the rejected sequences. Each rejected sequence starts with a valid prefix ending in state 1, followed by a w , and then followed by a sequence of arbitrary colors of length $n - i - 1$. \square

Identity 3 appears to relate Fibonacci numbers to powers of three. But appearances here are deceiving. Imagine here that we've hired a painter to paint our tilings and we've accidentally given him 4 colors. Essentially the same reasoning results in the following identity.

$$4^n = f_{2n+1} + (4-3) \sum_{i=1}^{n-1} 4^{n-i-1} f_{2i} + (4-2) \sum_{i=1}^{n-1} 4^{n-i-1} f_{2i-1}$$

The number of colors that we give our painter is, in fact, arbitrary and the identity is even valid for negative or irrational "numbers of colors," whatever that might mean. A similar problem will be seen in section 3.

3. AN IDENTITY BASED ON NON-MINIMAL AUTOMATA

One advantage of basing combinatorial proofs on automata is that there are infinitely many automata recognizing the same language. We can take advantage of this fact to prove Identity 4.

Identity 4. For n, p nonnegative integers, for b real (or even complex),

$$b^n = \sum_{j=0}^p \binom{p}{j} f_n^j f_{n-1}^{p-j} + \sum_{i=0}^{n-1} b^{n-i-1} \sum_{j=0}^p (b-2^j) \binom{p}{j} f_i^j f_{i-1}^{p-j}$$

This is a very general identity, which subsumes specific identities such as (1), when $b = 1$ and $p = 1$, and (2), when $b = 2$ and $p = 1$.

$$(1) \quad 1 = f_n + f_{n-1} - \sum_{i=0}^{n-1} f_i$$

$$(2) \quad 2^n = f_n + f_{n-1} + \sum_{i=0}^{n-1} 2^{n-i-1} f_{i-1}$$

The identity in (1) corresponds to Identity 1 in [1] and (2) corresponds to Identity 10. In [1] these two identities were proved in two very different ways. So it is interesting that there is a general formula that subsumes them both, along with an infinite variety of other identities for specific values of b and p .

We will prove Identity 4 in two different ways. The idea of the first proof is to count state sequences in an automaton with b states. By counting in non-minimal automata, the identity can be proved for $b \geq 2^p$. Then, since the identity is proven for an infinite number of instantiations for b , the identity can be extended by using what Knuth et al [3] call the "polynomial argument."

A nonzero polynomial of degree d or less can have at most d distinct zeros; therefore the difference of two such polynomials, which also has degree d or less, cannot be zero at more than d points unless it is identically zero. In other words, if two polynomials of degree d or less agree at more than d points, they must agree everywhere.

The polynomial argument can be used to extend the range of valid values for a combinatorially proven identity. But the price is that one loses a combinatorial interpretation for some of the values. For example, the identity in (1) would be interpreted as counting paths in an automaton for square-domino tiling with just one state. Perhaps there is an interpretation of such subminimal automata, but fortunately for us, the alternative proof presented at the end of this section removes the incentive for defining unusual automata with negative or irrational numbers of states.

Proof of special case. To prove Identity 4, we focus first on the special case where $b = 2^p$. The idea of the proof is shown in (3).

$$(3) \quad \begin{aligned} &\text{given an automaton with } b \text{ states,} \\ &b^n = \text{ number of successful state sequences of length } n \\ &\quad + \text{ number of unsuccessful state sequences of length } n \end{aligned}$$

We define, here, a state sequence to be “successful” if it corresponds to a path in the automaton, even if the sequence ends with a nonfinal state. Thus in Figure 1, 00 and 01 are successful and 011 is unsuccessful. Since every successful state sequence must begin with 0, the unique initial state, we can simplify some calculations by not considering the initial 0 to be part of the sequence. Thus 011 will be considered to be a sequence of length 2.

The identity schema in (3) can be instantiated with any finite state automaton. To prove Identity 4, we use an automaton with b states which recognizes p -tuples of square-domino tilings of length n . Note first that the minimal automaton recognizing p tilings of equal length has 2^p states. Thus the minimal automata recognizing a single tiling (Figure 1), a pair of tilings (Figure 8) and a triple of tilings (Figure 9) have 2, 4 and 8 states respectively.

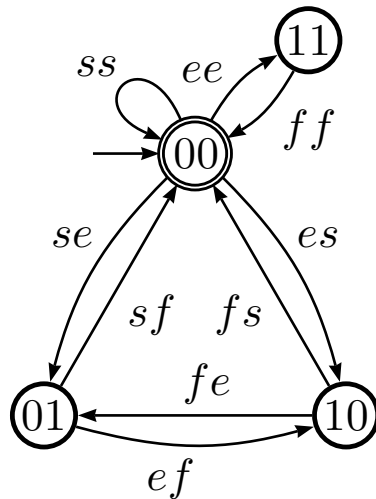

FIGURE 8. An automaton recognizing double tilings.

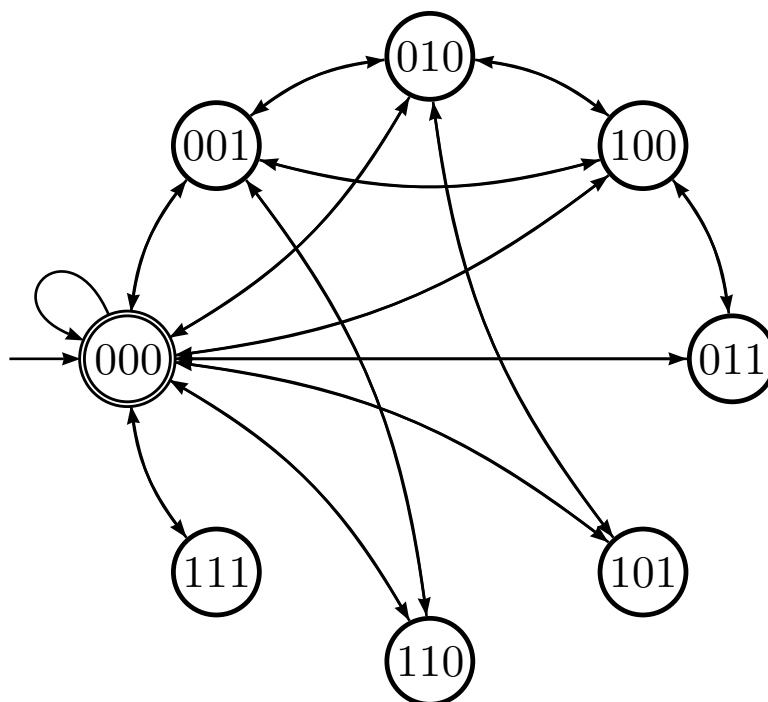

FIGURE 9. An automaton recognizing triples of tilings. Transition labels suppressed to avoid clutter.

In Figure 8, a transition labeled $t_1 t_2$ represents adding tile t_1 to the first board and t_2 to the second board. Transitions in Figure 9 are over triples of tiles, but the labels are suppressed in the figure to avoid clutter. Each state is labeled with a binary number of length p (the number of boards being tiled), where a zero as the i^{th} digit indicates a breakable cell in the i^{th} tiling, where a cell is said to be “breakable” if is covered with a square or the second half of a domino. Since the right language of a state is completely determined by the pattern of breakable and unbreakable cells that it describes, it is clear that the minimal automaton for a p -tuple of tilings will have 2^p states.

Moreover, each state labeled with a binary number with k zeros will have 2^k outgoing transitions, since any one of the breakable cells may be followed by either a square or the first half of a domino, whereas the unbreakable cells must be followed by the second half of a domino. Stated negatively, a state labeled with a binary number with k zeros in an automaton with b states will have $b - 2^k$ illegal successor states. In Figure 9, for example, the state 011 has 6 illegal successor states.

In a minimal automaton, the number of successful paths ending in a state labeled with a binary number with j 0's and $p - j$ 1's is $f_n^j f_{n-1}^{p-j}$ and since there are clearly $\binom{p}{j}$ such states, summing over all possible j results in: $\sum_{j=0}^p \binom{p}{j} f_n^j f_{n-1}^{p-j}$.

To count unsuccessful sequences of length n , we divide each such sequence into uvw , where u is a successful prefix, v is an illegal successor to the last state of

u , and w is an arbitrary sequence of states, successful or not. Suppose that the successful prefix is of length i . The number of successful paths, as seen above is $\sum_{j=0}^p \binom{p}{j} f_n^j f_{n-1}^{p-j}$, where j counts the number of 1's in the label of the final state of the sequence. As also seen above, the number of illegal successors is $b - 2^k$, where k counts the number of 0's. Since $k = j$, we can count the number of possibilities for uv with $\sum_{j=0}^p (b - 2^j) \binom{p}{j} f_i^j f_{i-1}^{p-j}$. Since w is of length $n - i - 1$, the number of arbitrary state sequences of this length is b^{n-i-1} . When we sum over all i , the remainder of the identity follows. \square

We have now proved Identity 4 for the special case where $b = 2^p$. To extend this to the case where $b > 2^p$, one needs to consider non-minimal automata such as that in Figure 10, in which there are equivalence classes of states such as $\{10, 10'\}$, all having the same right language. Essentially, the proof given above needs to be adapted to refer to these equivalence classes of states instead of singleton states. The details are fairly straightforward.

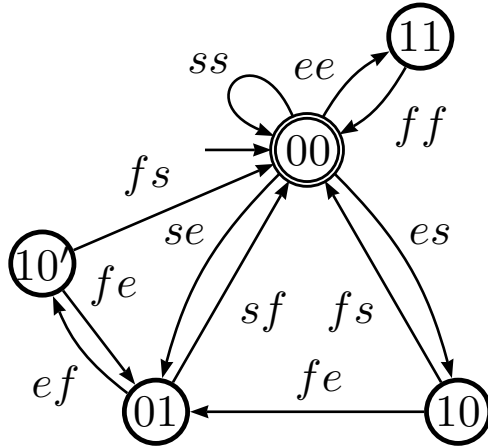

FIGURE 10. A 5-state, non-minimal automaton for double tilings.

By using non-minimal automata, the identity can then be proved for the infinite set of integer values for b such that $b \geq 2^p$. And once proven for an infinite set of values, the full range of possible values for b can be obtained by the polynomial argument.

3.1. Alternative Proof. The use of the polynomial argument is problematic for a combinatorial proof since it means that a combinatorial interpretation is missing for infinitely many values. One might perhaps accept some extended notion of automata on the grounds that the polynomial argument allows us to act as if automata with a negative or irrational number of states existed. One could argue, for example, for a state s in an automaton with -2 states, if s has four outgoing transitions, each to different states, then s must have -6 illegal successor states. The reasoning is entirely parallel to the reasoning in normal automata, and it

works fine. Fortunately, however, we can avoid such abstractions, since in this case, there is an alternative proof of Identity 4, which does not rely on the polynomial argument.

For the alternative proof, we begin with the following set of identities, from which only (4) and (5) will be needed for the proof.

$$\begin{aligned}
 (4) \quad & \text{for } n \geq 1, f_n^p = \sum_{i=0}^p \binom{p}{i} f_{n-1}^i f_{n-2}^{p-i} \\
 (5) \quad & \text{for } n \geq 2, f_n^p = \sum_{i=0}^p \binom{p}{i} f_{n-2}^i f_{n-3}^{p-i} 2^i \\
 (6) \quad & \text{for } n \geq 3, f_n^p = \sum_{i=0}^p \binom{p}{i} f_{n-3}^i f_{n-4}^{p-i} \sum_{j=0}^i \binom{i}{j} 2^{p-i+j} \\
 (7) \quad & \text{for } n \geq 4, f_n^p = \sum_{i=0}^p \binom{p}{i} f_{n-4}^i f_{n-5}^{p-i} \sum_{j=0}^i \binom{i}{j} \sum_{k=0}^{p-i+j} \binom{p-i+j}{k} 2^{k-j+i} \\
 & \quad \quad \quad \vdots
 \end{aligned}$$

The identity in (4) may be seen almost immediately in an automaton such as that in Figure 9. Essentially it just says that each state has a transition to the initial state, the state labeled with all 0's. So instead of counting paths of length n to each state, we can count the paths of length $n + 1$ to just the initial state.

The identity in (5) says that each state with i 0's in its label has 2^i paths of length 2 to the initial state. This is so since a state with i 0's has 2^i outgoing transitions, and each destination state of these transitions has one path of length one to the initial state.

The identity in (6) counts paths of length n by breaking them up into a prefix of length $n - 3$ followed by a suffix of length 3. Suppose that the suffix starts from a state s_1 labeled with $b_1 b_2 \dots b_p$ containing i 0 bits. A successor state s_2 to this state must be labeled with $d_1 d_2 \dots d_p$, where each (b_i, d_i) is one of $(0, 0)$, $(0, 1)$ or $(1, 0)$. The sequence $(1, 1)$ is ruled out, since this would correspond to having the first half of a domino on two neighboring cells. Suppose that j of the i 0 bits in $b_1 b_2 \dots b_p$ remain 0's in $d_1 d_2 \dots d_p$. There are $\binom{i}{j}$ ways to pick these j 0's. Together with the $p - i$ 1's that become 0's, there will then be $p - i + j$ 0's in $d_1 d_2 \dots d_p$. From the previous identity, we see that there will be 2^{p-i+j} paths of length 2 from s_2 to the initial state. Summing over all j , we see that there are $\sum_{j=0}^i \binom{i}{j} 2^{p-i+j}$ of length 3, from an arbitrary starting state with i 0's in its label. The identity is then obtained by summing over all paths of length $n - 3$ to a state with i 0's in its label.

The identity in (7) follows the same pattern. Given the first two of these identities, Identity 4 is trivial to prove.

Second proof. Substitute (4) and (5) into Identity 4. Expand the sums and reduce. \square

4. DISCUSSION

In this paper, we have proposed basing combinatorial proofs on path counting in automata as an alternative to tiling-based proofs. We certainly do not want to claim that the automata-based approach is better, only that it provides an alternative perspective. Identity 2, for example, could also be proved in a tiling approach by summing over tilings of length $n + 1$, where the second domino starts on cell i . Here the tiling proof is reasonably easy, and at best, the automata-based proof simply provides the “advantage” of connecting the proof to MSW lines, which may be independently interesting as evidenced by their connections to integer sequences A130578 and A005252 in the Online Encyclopedia of Integer Sequences. Similarly, the automata-based approach to tiling multiple boards in section 3 showed connections between seemingly unrelated identities. It is our hope that this approach will lead to new and interesting results.

APPENDIX A. IDENTITY TABLES

In the following tables, we list and categorize the set of identities derived from a very general schema. The idea is that with one kind of exception, any tiling can be partitioned into a prefix, infix and suffix, uvw such that u consists of a regularly repeating pattern, v consists of a sequence of tiles that breaks the pattern, and then w is an arbitrary tiling. The one exception is the case where the tiling consists of the regularly repeating pattern from beginning to end.

For example, suppose that the pattern consists of the set of tilings $\{sd, ds\}$. Then the prefix might look like $sdsddssd\dots$. Given this kind of prefix, what kind of infix might break the pattern? Two obvious possibilities are ss and dd , but sss , ssd , dds , etc would also be possibilities. The full set of blocking patterns, L , is $\Sigma^* - \text{prefix}(p\Sigma^*)$, where $\Sigma = \{s, d\}$, p is the set of strings in the pattern (all of the same length), and prefix is a function mapping a language to the set of prefixes of strings in the language. We will, however, be interested only in minimal blockers, which are not proper prefixes of any longer blocking patterns. So we define the set of blockers b as $L - (L\Sigma^* \cap L)$, the set of strings in L , which are not proper prefixes of other strings in L .

If the pattern p consists of strings of length k , then every tiling of length kn is either of the form p^* or $p^*b\Sigma^*$. The identities below all involve conditioning on the number of repetitions of p before b occurs. In many of the cases, the set b consists of strings of unequal length, so there is a second conditioning that depends on which particular string from b is used. In the tables, the strings in b are grouped according to length.

Each identity is expressed in the table in a form that is easily provable given the pattern and blocker. The tables are followed by simplified identities, in which terms have been grouped. The particular simplifications are sometimes rather arbitrary. All of the identities are valid for $n \geq 0$.

A.1. Pattern of Length 1.

N	Pattern	Blocker	Identity
1	s	d	$f_n - 1 = \sum_{i=0}^{n-2} f_{n-i-2}$

A.1.1. *Simplification.* This identity may be simplified in two different ways: 1a shows the similarity to Identity 1 in [1], and 1b shows the similarity to the final identity in each of the following tables.

- 1a. $f_n - 1 = f_0 + f_1 + \cdots + f_{n-2}$
- 1b. $f_n - 1 = 1(1^{n-2}f_0 + 1^{n-3}f_1 + \cdots + 1^0f_{n-2})$

A.2. Patterns of Length 2.

N	Pattern	Blocker	Identity
1	ss	$d \mid sd$	$f_{2n} - 1 = \sum_{i=0}^{n-1} f_{2n-2i-2} + \sum_{i=0}^{n-2} f_{2n-2i-3}$
2	d	s	$f_{2n} - 1 = \sum_{i=0}^{n-1} f_{2n-2i-1}$
3	$d \mid ss$	sd	$f_{2n} - 2^n = \sum_{i=0}^{n-2} 2^i f_{2n-2i-3}$

A.2.1. Simplifications.

1. $f_{2n} - 1 = \sum_{i=0}^{2n-2} f_i$
2. $f_{2n} - 1 = \sum_{i=1}^n f_{2i-1}$ (Identity 13 in [1])
3. $f_{2n} - 2^n = 1(2^{n-2}f_1 + 2^{n-3}f_3 + \cdots + 2^0f_{2n-3})$

A.3. Patterns of Length 3.

N	Pattern	Blocker	Identity
1	sss	$(d) \mid (sd) \mid (ssd)$	$f_{3n} - 1 = \sum_{i=0}^{n-1} f_{3n-3i-2} + \sum_{i=0}^{n-1} f_{3n-3i-3} + \sum_{i=0}^{n-2} f_{3n-3i-4}$
2	ds	$(s) \mid (dd)$	$f_{3n} - 1 = \sum_{i=0}^{n-1} f_{3n-3i-1} + \sum_{i=0}^{n-2} f_{3n-3i-4}$
3	sd	$(d \mid ss)$	$f_{3n} - 1 = 2 \sum_{i=0}^{n-1} f_{3n-3i-2}$
4	$sss \mid ds$	$(sd) \mid (dd \mid ssd)$	$f_{3n} - 2^n = \sum_{i=0}^{n-1} 2^i f_{3n-3i-3} + 2 \sum_{i=0}^{n-2} 2^i f_{3n-3i-4}$
5	$sss \mid sd$	$(d) \mid (ssd)$	$f_{3n} - 2^n = \sum_{i=0}^{n-1} 2^i f_{3n-3i-2} + \sum_{i=0}^{n-2} 2^i f_{3n-3i-4}$
6	$ds \mid sd$	$(ss) \mid (dd)$	same as 5
7	$sss \mid ds \mid sd$	$(dd) \mid (ssd)$	$f_{3n} - 3^n = 2 \sum_{i=0}^{n-2} 3^i f_{3n-3i-4}$

A.3.1. Simplifications.

1. $f_{3n} - 1 = \sum_{i=0}^{3n-2} f_i$ (Identity 1 in [1], variant)
2. $f_{3n} - 1 = 2f_3 + 2f_5 + \cdots + 2f_{3n-4} + f_{3n-1}$
3. $f_{3n} - 1 = 2 \sum_{i=0}^{n-1} f_{3i+1}$ (Identity 24 in [1])
4. $f_{3n} - 2^n = 2^{n-1}(f_0 + f_2) + 2^{n-2}(f_3 + f_5) + \cdots + 2(f_{3n-6} + f_{3n-4}) + f_{3n-3}$
5. same as 4
6. same as 4
7. $f_{3n} - 3^n = 2(3^{n-2}f_2 + 3^{n-3}f_5 + \cdots + 3^0f_{3n-4})$

A.4. Patterns of Length 4. Only patterns and blockers are given. Identities and simplifications available upon request to the second author.

N	Pattern	Blocker
1	$ssss$	$(d) \mid (sd) \mid (ssd) \mid (sssd)$
2	ssd	$(d) \mid (sd \mid sss)$
3	sds	$(d \mid ss) \mid (sdd)$
4	dss	$(s) \mid (dd) \mid (dsd)$
5	dd	$(s) \mid (ds)$
6	$ssss \mid ssd$	$(d) \mid (sd) \mid (sssd)$
7	$ssss \mid sds$	$(d) \mid (ssd) \mid (sssd \mid sdd)$
8	$ssss \mid dss$	$(sd) \mid (dd \mid ssd) \mid (sssd \mid dsd)$
9	$ssss \mid dd$	$(ds \mid sd) \mid (ssd) \mid (sssd)$
10	$ssd \mid sds$	$(d) \mid (sss) \mid (sdd)$
11	$ssd \mid dss$	$(sd \mid sss) \mid (dd) \mid (dsd)$
12	$ssd \mid dd$	$(sss \mid sd \mid ds)$
13	$sds \mid dss$	$(ss) \mid (dd) \mid (sdd \mid dsd)$
14	$sds \mid dd$	$(ss) \mid (ds) \mid (sdd)$
15	$dss \mid dd$	$(s) \mid (dsd)$
16	$ssss \mid ssd \mid sds$	$(d) \mid (sdd \mid sssd)$
17	$ssss \mid ssd \mid dss$	$(sd) \mid (dd) \mid (dsd \mid sssd)$
18	$ssss \mid ssd \mid dd$	$(ds \mid sd) \mid (sssd)$
19	$ssss \mid sds \mid dss$	$(dd \mid ssd) \mid (dsd \mid sssd \mid sdd)$
20	$ssss \mid sds \mid dd$	$(ds) \mid (ssd) \mid (sssd \mid sdd)$
21	$ssss \mid dss \mid dd$	$(sd) \mid (ssd) \mid (sssd \mid dsd)$
22	$ssd \mid sds \mid dss$	$(sss) \mid (dd) \mid (dsd \mid sdd)$
23	$ssd \mid sds \mid dd$	$(ds \mid sss) \mid (sdd)$
24	$ssd \mid dss \mid dd$	$(sd \mid sss) \mid (dsd)$
25	$sds \mid dss \mid dd$	$(ss) \mid (sdd \mid dsd)$
26	$ssss \mid ssd \mid sds \mid dss$	$(dd) \mid (dsd \mid sdd \mid sssd)$
27	$ssss \mid ssd \mid sds \mid dd$	$(ds) \mid (sdd \mid sssd)$
28	$ssss \mid ssd \mid dss \mid dd$	$(sd) \mid (dsd \mid sssd)$
29	$ssss \mid sds \mid dss \mid dd$	$(ssd) \mid (dsd \mid sdd \mid sssd)$
30	$ssd \mid sds \mid dss \mid dd$	$(sss) \mid (dsd \mid sdd)$
31	$ssss \mid ssd \mid sds \mid dss \mid dd$	$(dsd \mid sssd \mid sdd)$

REFERENCES

- [1] Arthur T. Benjamin and Jennifer Quinn, *Proofs that really count: The art of combinatorial proof*, The Mathematical Association of America, Washington, D.C., 2003.
- [2] R. A. Deninger, *Fibonacci numbers and water pollution control*, *Fibonacci Quarterly* **10** (1972), no. 3, 299–300.
- [3] Ronald L. Graham, Donald E. Knuth, and Oren Patashnik, *Concrete mathematics: A foundation for computer science*, 2nd ed., Addison-Wesley Longman Publishing Co., Inc., Boston, MA, USA, 1994.
- [4] Leo Moser, *Problem B-6: Some reflections*, *Fibonacci Quarterly* **1** (1963), no. 4, 75–76.

DEPT. MATHEMATICS, HARVEY MUDD COLLEGE, CLAREMONT, CALIFORNIA, 91711

DEPT. LINGUISTICS, UNIVERSITÄT TÜBINGEN, D-72074 TÜBINGEN